

Living d.o.o.
Goriška cesta 66A
SI-5270 Ajdovščina
Slovenija

Tel.: +386 (0)5 333 38 10
+386 (0)5 333 30 70
Fax.: +386 (0)5 333 30 71
e-mail: living@siol.net



Peskalni stroji Shotblast machines



STROJI Z VISEČO KLJUKO

Obdelovanci visijo na kljukih, ki se vrte in oscilirata med peskanjem za določen čas.

BATCH HOOK MACHINES

Workpieces are hanged on hooks that rotate or rotate and oscillate in blasting position for a preset time.



Living d.o.o.
Goriška cesta 66A
SI-5270 Ajdovščina
Slovenija

Tel.: +386 (0)5 333 38 10
+386 (0)5 333 30 70
Fax.: +386 (0)5 333 30 71
e-mail: living@siol.net

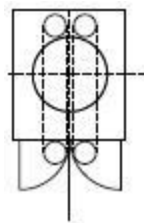

- A) Obdelovanci visijo na ročnem vozičku.
 - B) Obdelovanci visijo električnem vozičku (dvigalu).
-
- A) Load hanging on manually operated trolley.
 - B) Load hanging on el. operated trolley (hoist).

Stroj izvedbe B s šaržirno napravo.
 Machine execution B with loading device.

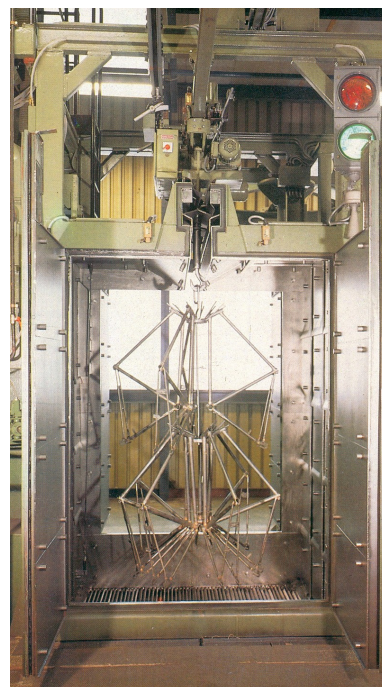
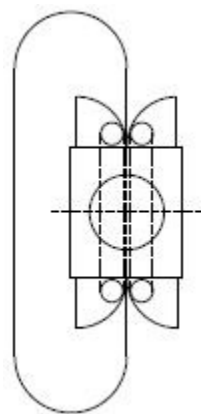

Stroj tipa B.
 Machine type B.

- C) Obdelovanci visijo na ročnem vozičku.
- D) Obdelovanci visijo električnem vozičku (dvigalu).

- A) Load hanging on manually operated trolley
- B) Load hanging on electrically operated trolley (hoist).

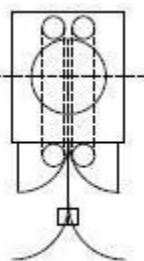

- A) Obdelovanci visijo na ročnem vozičku.
- B) Obdelovanci visijo električnem vozičku (dvigalu).
- C) Ročna ali električna kretnica.

- A) Load hanging on manually operated trolley
- B) Load hanging on el. Operated trolley (hoist)
- C) Diverter operated manually or pneumatically

Stroj tipa A.
 Machine type A.

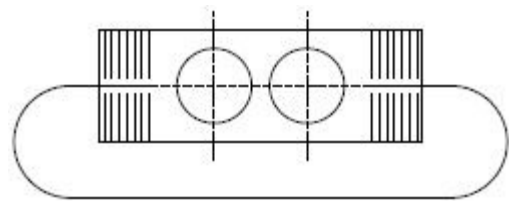

- A) Obdelovanci obešeni na visečem transporterju
- B) Možnost več pozicij za peskanje. Stroj opremljen s tesnilnimi zavesami.

- A) Load hanging on indexing powered monorail conveyor
- B) One or more blasting positions with inlet and outlet sealing vestibules



Stroj tipa A.
 Dve poziciji za peskanje.
 Machine type A.
 Two blasting positions.

BM 1000 x 1200

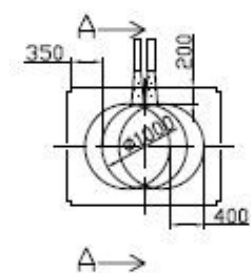

BM 1200 x 1600

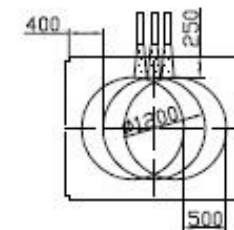

BM 1600 x 2000

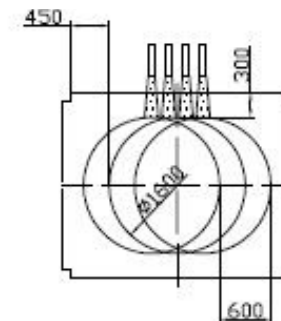

BM 2200 x 3000

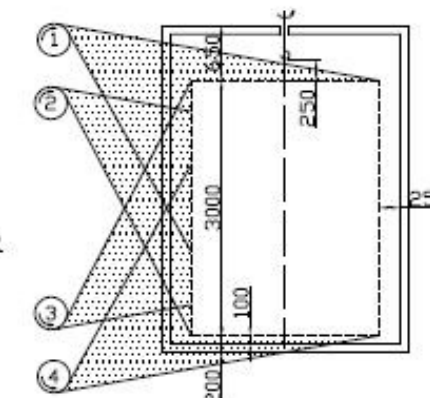
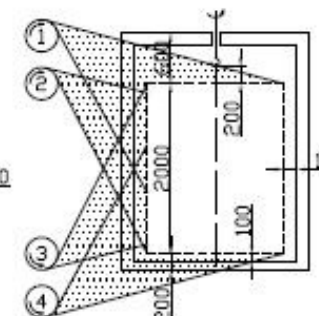
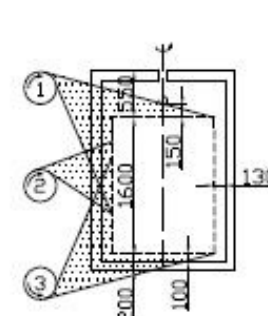
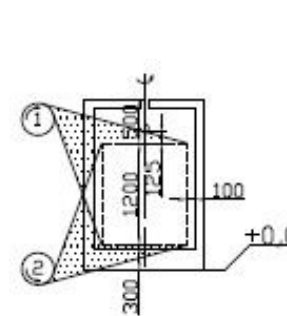
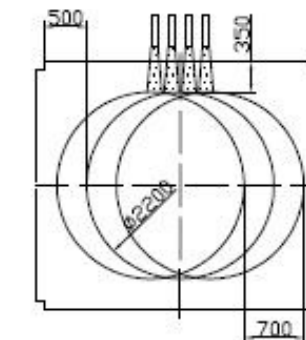

Nosilnost vozička

- Do 5.000 kg z električnim vozičkom.
- Do 1.500 kg z ročnim vozičkom.
- Do 1.500 kg na visečem transporterju.

Turbine 380 D/T ali 320 D

- 380 D z direktnim pogonom moči od 11 do 30 kW.
- 380 T z vretenjakom moči od 11 do 45 kW.
- 320 D z direktnim pogonom moči od 5,5 do 11 kW.

Hook load

- Up to 5.000 kg with electrically operated trolley and hoist
- Up to 1.500 kg with hooks hanging on manually operated trolleys
- Up to 1.500 kg with powered overhead conveyor

Throwing wheels 380 D/T, alternatively 320 D

- 380 D Directly driven powered by motors from 11 up to 30 kW.
- 380 T Indirectly driven by spindle powered by motors from 11 up to 45 kW.
- 320 D Directly driven powered by motors from 5,5 up to 11 kW.

Separatorji peska

- Zračni separator.
- Zračni separator s sitom
- Magnetni separator

Transport peska

- Polžni transporter - elevator
- Vibracijski transporter - elevator

Dodatna oprema

- Avtomatsko doziranje peska

Nakladalne naprave

Abrasive separators

- Cascade air wash type
- Rotary screen air wash
- Rotary screen magnetic air wash

Abrasive conveying

- Screw conveyor - bucket elevator
- Vibrating conveyor - bucket elevator

Auxiliary equipment

- Automatic abrasive replenisher

Loading devices